

KIMTECH Fiber Cleaver



Kimtech

COMMUNICATIONS





Instructions fiber cleaver:

1, Before Use Please read these instructions carefully;

2, cleaver knife is precision machinery, can not withstand strong impact, so as not to affect the cutter performance

3, Optical fiber and optical fiber debris is very slim, and the tip of a sharp, use strictly prevent fiber debris from entering the skin, eyes, optical fiber debris with special container collection

4, Do not directly touch the blade, maintenance, do not touch the blade;

5, Do not split the cutter or to its oil needs repair, please contact the manufacturers service department

1.Basic Specifications

Applicable fiber	Quartz fiber
quartz fiber cutting	125μm
fiber coating diameter	250 ~ 900μm
cutting angle	less than 0.5 ° (single fiber)
Cutting length	13mm
Blade cutting life	<p>25,00 times * 16 surface</p> <p>rotation using imported ultrafine particles of tungsten steel alloy made of rigid material, the international leader in process of production from the edge of the mirror surface finish, quality is stable and reliable</p> <p>100 times magnification zoom blade, into a complete curve, no uneven</p> <p>Chipping blade under the microscope at 200 times as 0.003mm:</p>
Cutter size / weight	<p>70L × 54W × 58H (mm) / 238g</p> <p>(150g, length 70 * 54 * 52 feature on the machine)</p>

2. Structure

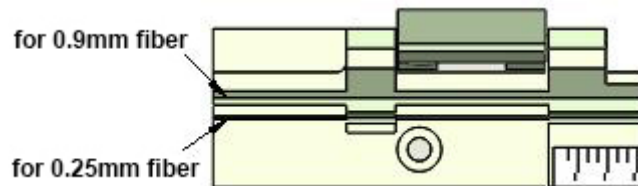
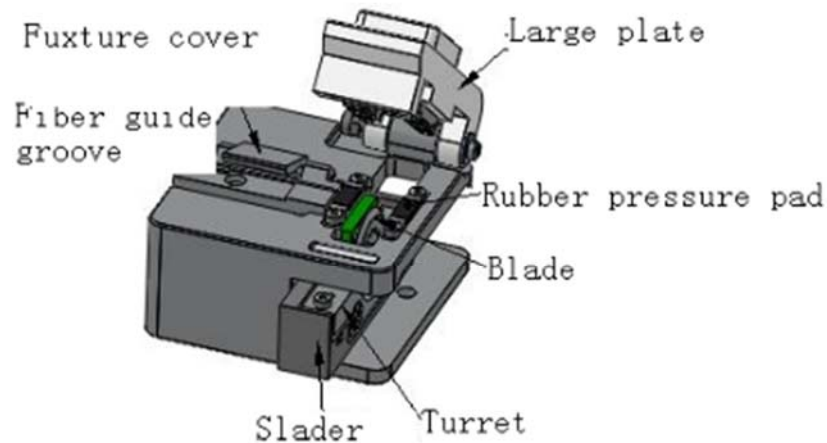

3. Operating Method

1, large platen opening and closing lever lift open large platen fixture cover the blade slider pushed to the front side of device, waste fiber recycling the superstructure will automatically open;

2, with the stripped fiber clamp stripped fiber coating reserved for bare fiber length 35-45mm, moistened with alcohol cotton wool or tissue paper wrap optical fiber, fiber clean. Wiping with cotton wool or tissue, do not use the same cotton wool or tissue paper to rub the second (Note: Please purity greater than 99% alcohol);

3, visual to the edge of the fiber coating layer is aligned with the cutter on the ruler (10-16cm) appropriate scale, left the optical fiber into the fiber guide grooves require a bare

fiber placed straight on the optical fiber pressure pad to determine the end of the fiber can be touched recycler the rollers;

4 Close the fixture cover platen, to promote the device blade slider, the blade dicing the lower surface of the optical fiber, and is free to slide to the other side, cut off the fiber;

5, left hand held onto the cutter right hand to open the large platen waste fiber will automatically be placed in the waste fiber collection box,;

6, With the left hand and hold the optical fiber while his right hand to open the fixture cover, carefully remove the fiber cut end face: the neat fiber cross-section not to touch and it is matter

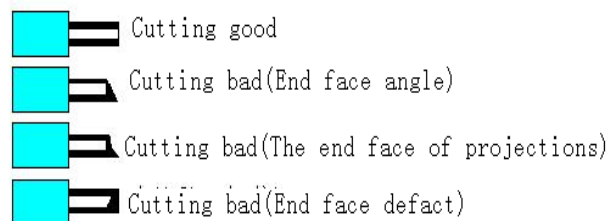

7, Troubleshooting, cutting bad reasons may be:

- 1), fiber is not straight on the fiber-optic pressure pad;
- 2), the blade height is too high;
- 3), blade, sanding pad dust and other foreign matter

4. Maintenance

1, the day-to-day cleaning, often with moistened with alcohol cotton swab to clean optical fiber pressure pad up and down the rubber surface and the edge portion of the blade, cut ineffective shall promptly clean fiber fixture trench also need to be cleaned; waste fiber collection box is full, the pinch after the first down, and then outward can remove fiber debris poured into special containers for collection;

2 blade mouth of the adjustment method, multiple cutting blade occurs

consumption will appear continuously cut, cutting the surface defects of the

phenomenon, the need to adjust the position of the blade mouth:



- A, (without removing) the blade locking screw wrench to loosen;
- B, with a cotton swab withstood blade, rotary blade, the blade is screwed to the next new edge;
- C, with a wrench and tighten the blade locking screw must be sure they are tight;
- D, try cutting 1,2 times fiber, fiber cut end surface, such as the end face of adverse welding machine screen viewing, adjust the blade height.

 Do not adjust the position of the mouth of the blade with bare hands to turn the blade, so as not to cause harm; Do not rotating tweezers and other metal blade, so as not to damage the blade

3, the blade height adjustment

A, Push the slider to the position when the cut is complete.

B, according to the height adjustment screws need to be towards the desired direction and tighten the screw a little height locking screw clockwise to increase, counterclockwise to lower.

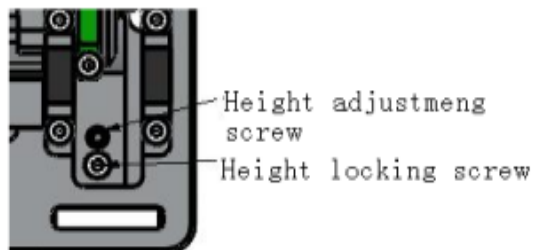

4, prone to problems and adjustment method:

A、 fiber cut constantly bump phenomenon, a beveled;

This problem occurs when the cutter fully adjusted by the above method may be too low, causing the blade, adjust the blade height above.

B、 cracks optical fiber, optical fiber end face shadow, fiber angle;

May be the blade is too high, lower the blade height above.

C、 low, high blade bevel large blade;

This is mainly caused by the fiber end face cracks observed near the fiber end face shadow and may occasionally cracks the surface is not aligned microscope direction.

5, the cycle of the blade use

The blade as the circle of the rule from the theory on the circle arbitrary point Jie neng cutting more than 1,000 times,, 1-16 of the region between the cutting operation can also select the number of points.

The position of the blade 1-16 All After use, referring to adjust the blade height, the blade height is adjusted to a position of a higher number from 1-16, there may be repeated using a loop.

6, the replacement of the blade

A, with a wrench to loosen the blade locking screw and remove the locking screws and gaskets;

B, open large platen, the tweezers carefully grip the blade on both sides, gently lift the blade removed, put away;

C clamp the clamp new blade, flat blade, slightly higher than the position of the blade shaft into them, falling into the shaft of the blade hole up against the blade with a cotton swab, rotate the blade so that the blade rotates to 1:00;

D, blade gasket on the corresponding position on the blade, screw on and tighten the locking screw.



Use tweezers, forceps do not touch the blade, so as not to affect the cutting performance.